

# #910 CLASSIC 10 GUN CABINET ASSEMBLY INSTRUCTIONS

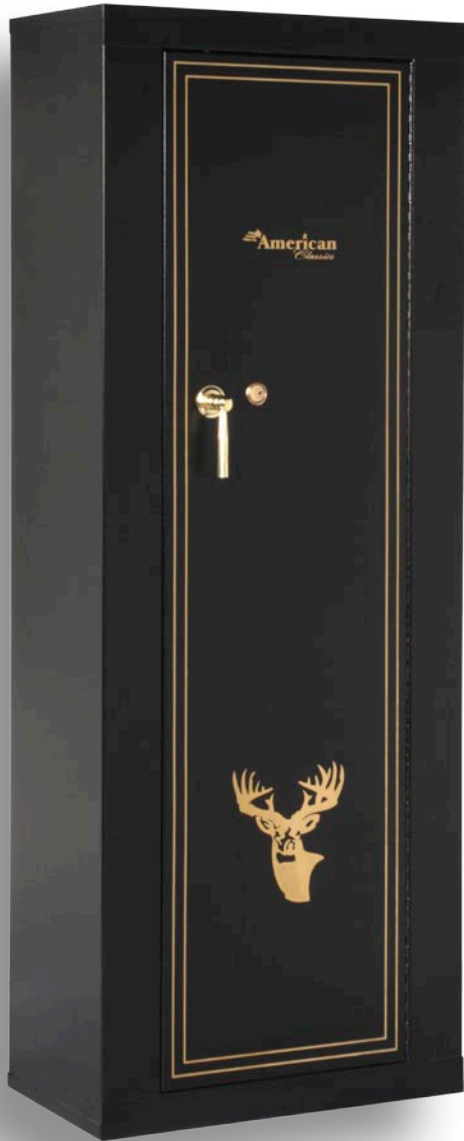

 **American**  
**Furniture Classics**  
A division of Dawson Heritage Furniture

Thank you for purchasing this quality product. A list of PARTS and INSTRUCTIONS is included to assist you. Unpack and identify all parts included on the Parts List and Hardware List. If parts are missing, please DO NOT return this item to the store. For faster service please call our **Customer Service Department at 1-888-673-9080**. For efficient and speedy service, please indicate the model number and code letter of part(s) needed.

# #910 CLASSIC 10 GUN CABINET ASSEMBLY INSTRUCTIONS



## HARDWARE LIST

- |   |  |                                 |   |  |                                    |   |  |                                 |
|---|--|---------------------------------|---|--|------------------------------------|---|--|---------------------------------|
| 1 |  | <b>M6X12 LCK</b><br>QTY: 8 SETS | 4 |  | <b>SHELF LOCK</b><br>QTY: 8 PCS    | 7 |  | <b>DOOR KEY</b><br>QTY: 1 SET   |
| 2 |  | <b>M6X8 RND</b><br>QTY: 4 SETS  | 5 |  | <b>FLOOR LEVELER</b><br>QTY: 2 PCS | 8 |  | <b>SHELF SUPPORT</b><br>X 8 PCS |
| 3 |  | <b>M4X10</b><br>QTY: 10 SETS    | 6 |  | <b>DOOR HANDLE</b><br>QTY: 1 PCS   | 9 |  | <b>WRENCH</b><br>X 1 PCS        |

## PARTS LIST

- |   |                                       |   |                                   |   |                                       |
|---|---------------------------------------|---|-----------------------------------|---|---------------------------------------|
| A | <b>METAL BACK PANEL</b><br>QTY: 1 PCS | D | <b>BOTTOM PANEL</b><br>QTY: 1 PCS | G | <b>ADJUSTABLE SHELF</b><br>QTY: 1 PCS |
|   |                                       |   |                                   |   |                                       |
| B | <b>LEFT SIDE PANEL</b><br>QTY: 1 PCS  | E | <b>TOP PANEL</b><br>QTY: 1 PCS    | H | <b>BARREL REST</b><br>QTY: 1 PCS      |
|   |                                       |   |                                   |   |                                       |
| C | <b>RIGHT SIDE PANEL</b><br>QTY: 1 PCS | F | <b>DOOR</b><br>QTY: 1 PCS         | J | <b>WOOD BACK PANEL</b><br>QTY: 1 PCS  |
|   |                                       |   |                                   |   |                                       |

## CUSTOMER SERVICE

Toll Free 888-673-9080 • Fax 417-673-9081 • E-mail [service@americanfurnitureclassics.com](mailto:service@americanfurnitureclassics.com)

# #910 CLASSIC 10 GUN CABINET ASSEMBLY INSTRUCTIONS

## STEP

### 1

**A METAL BACK PANEL**

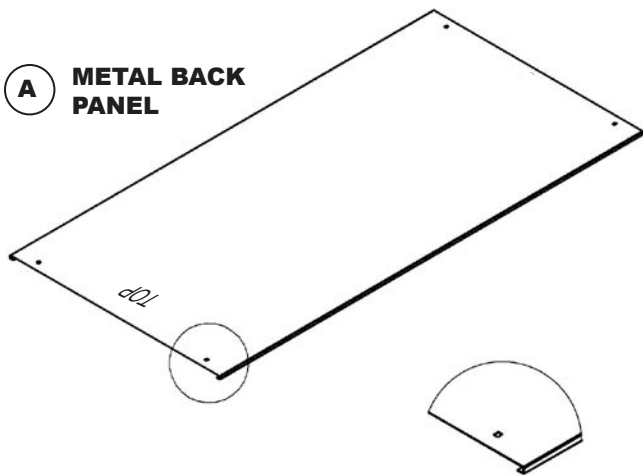

LAY METAL BACK PANEL ON FLOOR WITH INSIDE OF BACK PANEL FACING UP.

## STEP

### 2

#### NOTE

HOLES/SLOTS IN CABINET SIDES FOR ADJUSTABLE SHELF BARREL REST MUST BE TOWARD TOP CABINET

**B LEFT SIDE PANEL**

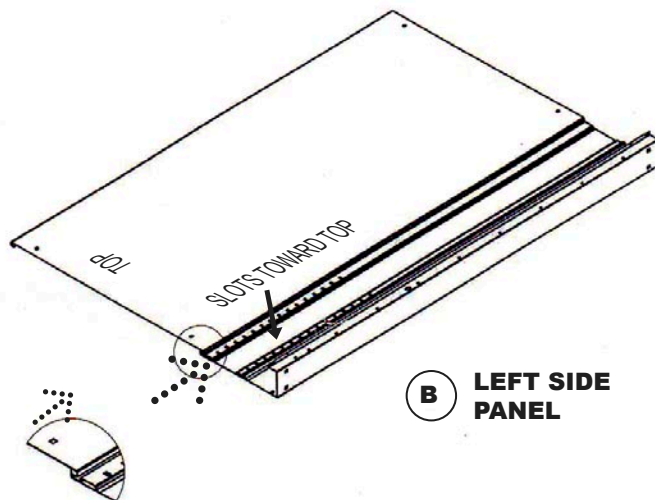

HOOK / ATTACH LEFT SIDE PANEL TO BACK PANEL.

## STEP

### 3

**C RIGHT SIDE PANEL**

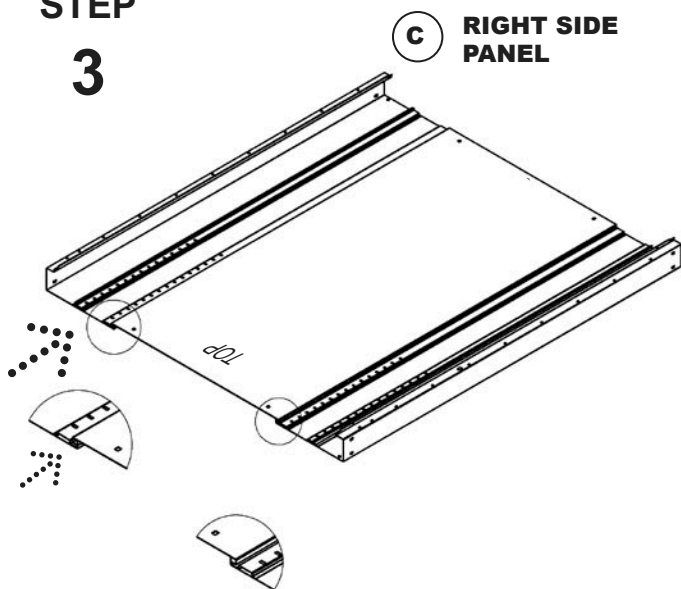

HOOK / ATTACH RIGHT SIDE PANEL TO BACK PANEL.

## STEP

### 4

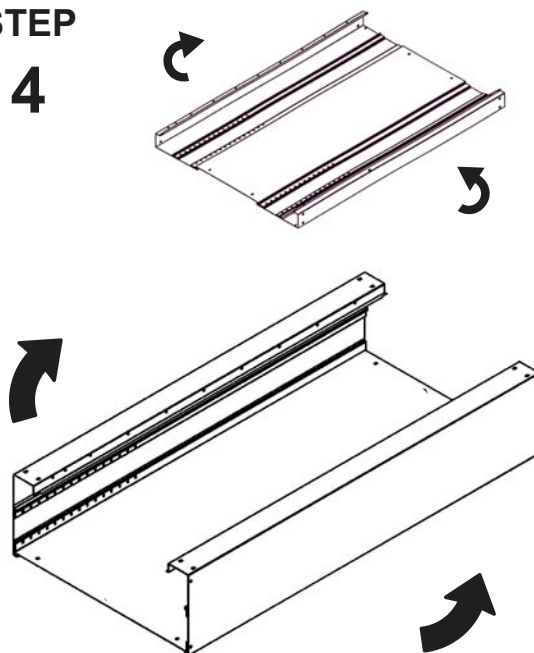

ROTATE FRONT EDGE OF BOTH SIDE PANELS UPWARD TO FORM RECTANGULAR CABINET SHAPE.

# #910 CLASSIC 10 GUN CABINET ASSEMBLY INSTRUCTIONS

## STEP

### 5

### IMPORTANT

DO NOT FULLY TIGHTEN THE BOLTS DURING THIS STEP.

#### D BOTTOM PANEL

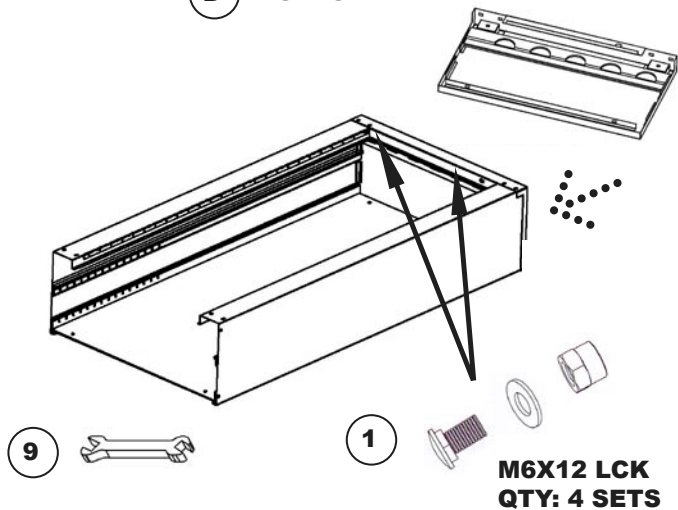

SLIDE BOTTOM PANEL OVER THE SIDE AND BACK PANELS. INSERT 4 - M6X12 BOLTS THROUGH FRONT AND LOOSELY TIGHTEN WASHER & LOCK NUTS FROM INSIDE.

## STEP

### 6

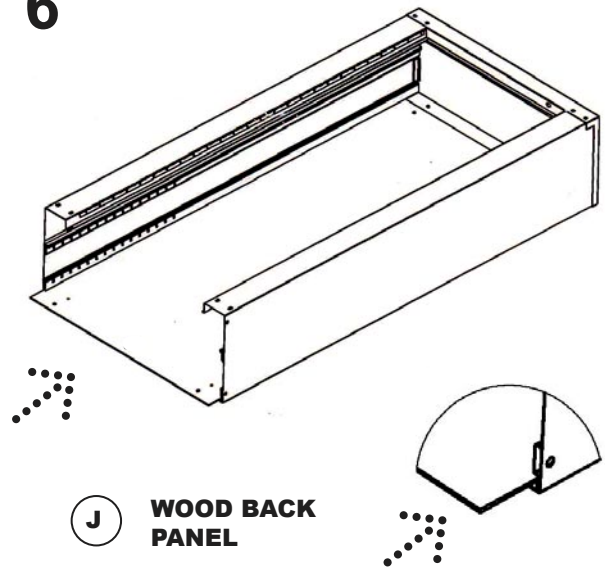

INSERT AND SLIDE WOOD BACK PANEL INTO PLACE FROM TOP END OF CABINET.

## STEP

### 7

#### 1 M6X12 LCK QTY: 4 SETS

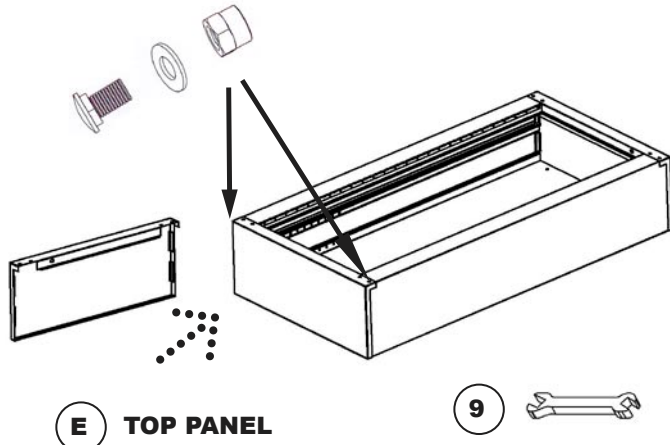

SLIDE TOP PANEL OVER THE SIDE, CENTER AND BACK PANELS. INSERT 4 - M6X12 BOLTS THROUGH FRONT AND FULLY TIGHTEN WASHER & LOCK NUTS FROM INSIDE USING WRENCH.

## STEP

### 8

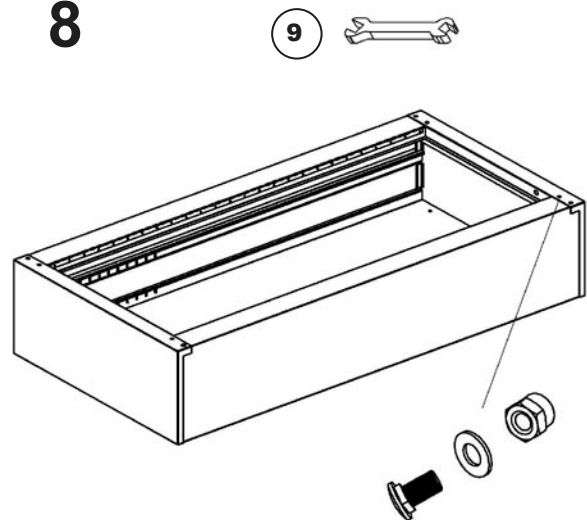

RETURN TO BOTTOM PANEL AND FULLY TIGHTEN THE 4 - M6X12 BOLTS FROM INSIDE USING THE WRENCH.

# #910 CLASSIC 10 GUN CABINET ASSEMBLY INSTRUCTIONS



## STEP

### 9

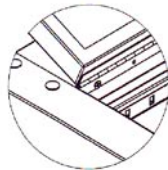
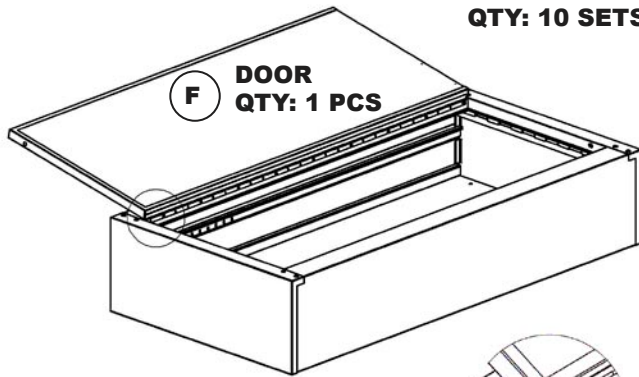

FOLD DOOR HINGE FULLY OPEN. LAY DOOR ONTO LEFT FRONT FRAME OF CABINET. LINE UP PRE-DRILLED HOLES IN HINGE AND DOOR FRAME. INSERT M4X10 THROUGH DOOR HINGE AND ATTACH NUT FROM INSIDE AND FULLY TIGHTEN USING WRENCH.

## STEP

### 10

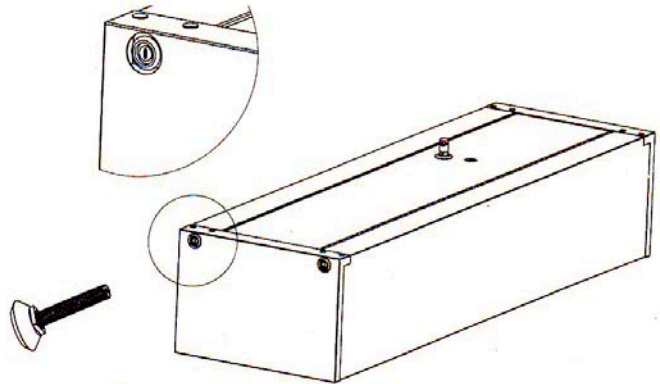

SCREW FLOOR LEVELERS INTO THE SCREW HOLE ON THE BOTTOM OF THE CABINET.

## STEP

### 11

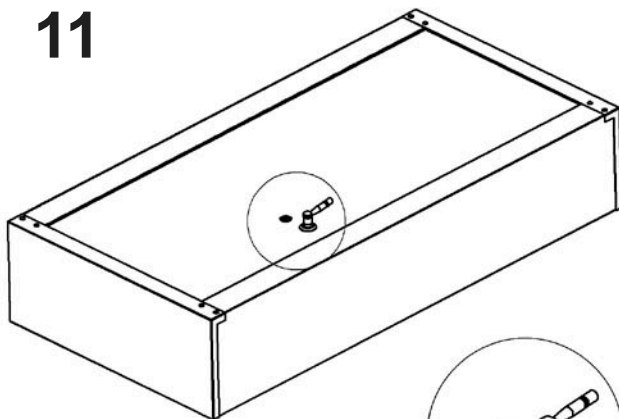

SCREW LOCK HANDLE INTO DOOR. OPEN AND CLOSE DOOR TO CONFIRM PROPER ALIGNMENT.

## STEP

### 12

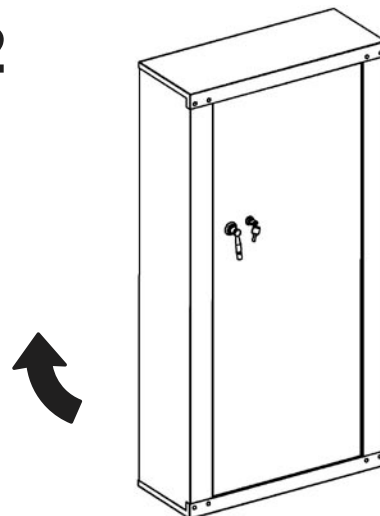

LIFT CABINET TO VERTICAL POSITION.

# #910 CLASSIC 10 GUN CABINET ASSEMBLY INSTRUCTIONS

## STEP 13

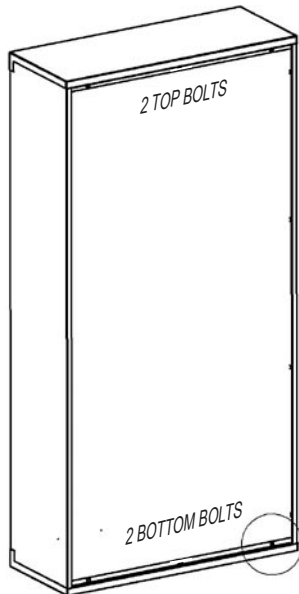

INSERT 4 - M6X8 RND BOLTS THROUGH BACK AND FULLY TIGHTEN WASHER & ROUND HEADED LOCK NUTS FROM INSIDE USING M6 WRENCH.

## STEP 14

**G** ADJUSTABLE SHELF  
QTY: 1 PC

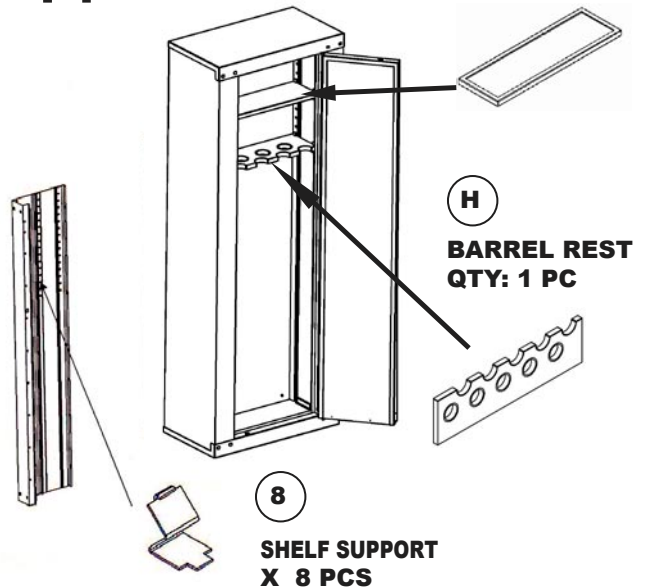

INSERT METAL STORAGE SHELVE AND BARREL REST IN THE CABINET USING SHELF SUPPORTS IN THE DESIRED LOCATION.

## STEP 15

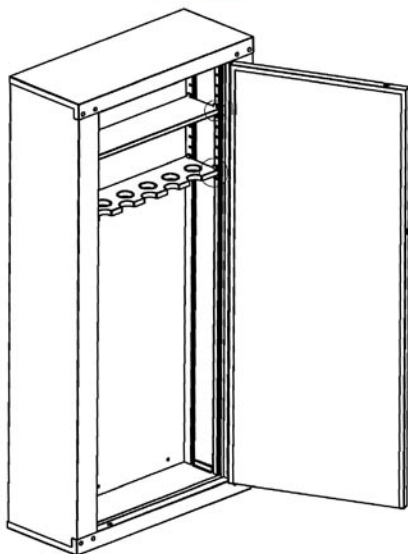

**4**  
SHELF LOCK  
QTY: 8 PCS

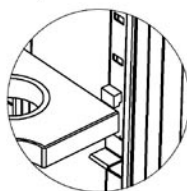

## Customer Service

• Toll Free 888-673-9080

• Fax 417-673-9081

• E-mail

[service@americanfurnitureclassics.com](mailto:service@americanfurnitureclassics.com)

INSERT PLASTIC SAFETY CLIP ABOVE ALL SHELVES AND BARREL RESTS.